

Photomultipliers & Photodiodes

Features: Photomultipliers

- 10 mm, 25 mm and 40 mm
- Single, chevron or z-stack MCP options with gain up to 3×10^7
- UV, Solar Blind, Visible and NIR responses
- Rise time to 60 ps (model dependant)
- FWHM to 100 ps (model dependant)
- Single photon jitter to 28 ps
- Multi-photon jitter below 10 ps
- Fast pulse output linear up to 1 A
- Fast gating to 2 ns
- Integral 50 ohm output

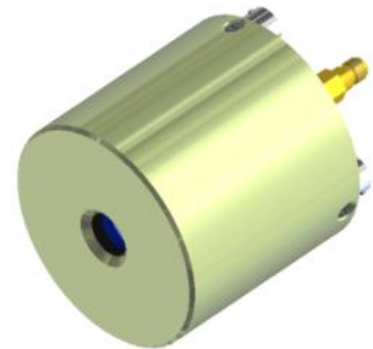

Features: Photodiodes

- 10 mm, 25 mm and 40 mm
- Unity gain
- UV, Solar Blind, Visible and NIR responses
- High dynamic range
- Linear response measured up to TBD amps per square centimetre
- Rise time < 100 ps
- Integral 50 ohm output

Applications

- Analysis of fast optical pulses
- Cherenkov light detection
- Fluorescence spectroscopy
- LIDAR
- Particle & Nuclear physics
- Single photon counting fluorescence
- Time correlated photon counting

General Description

Photek is the world leading manufacturer of photomultipliers & photodiodes for analysis of ultra fast optical phenomena in a range of applications including, LIDAR, nuclear physics and time correlated photon counting. Photek manufactures 10, 25 and 40 mm photomultipliers & photodiodes for use in the UV, visible and NIR spectrum. Photek's photomultipliers & photodiodes are the fastest in the world with pulse rise times to 50 ps and pulse FWHM to 80 ps. For applications where gating is required the Photek photomultipliers can provide gated speeds to 2 ns.

Photek Limited

26 Castleham Road, St Leonards on Sea,
 East Sussex, TN38 9NS, United Kingdom.
T +44 (0)1424 850555 **F** +44 (0)1424 850051
E sales@photek.co.uk **W** www.photek.co.uk

Datasheet No.	DS006
Issue	DR
Date	24 August 2010

Input Window

Photek photomultipliers and photodiodes are available with a choice of input window materials. These include MgF₂, fused silica, glass and fibre optic

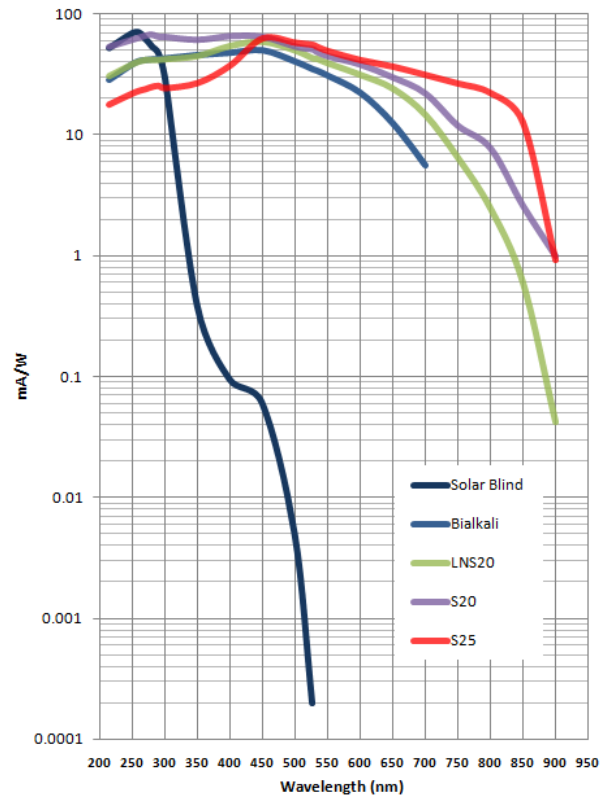
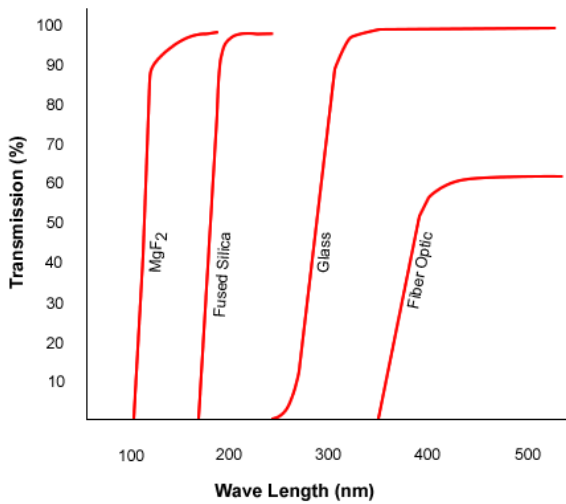

Gain

Photek photomultipliers can be provided with 1, 2 or 3 micro channel plates for gain up to 3 × 10⁷. Photek photodiodes have no MCPs and provide unity gain

MCPs	Maximum Electron Gain
0	Unity gain (photodiode)
1	5 × 10 ³
2	1 × 10 ⁶
3	3 × 10 ⁷

Electrical

-5KV @ 200 μA for all PMTs

Spectral Response

Photek offer a full range of Gen II photocathodes, these include CsI, Solar Blind, Bialkali, Low Noise S20, S20 and S25.

The above curves represent the broad spectral response that you would expect to achieve with Photek’s range of Gen II photocathodes. Please note that input window material and fast gating requirement will affect overall sensitivity.

For fast gating below 10 ns, a photocathode with a mesh underlay is required.

Environmental Testing

For applications where the photomultiplier and photodiode is exposed to temperature and shock conditions Photek has the appropriate facilities to offer environmental stress screening. Our vibration system offers shock, sine, random and sine on random testing. Our thermal chamber has a temperature range of -75 °C to +160 °C and can control humidity from 10% to 98%.

Environmental

Operational Limits: -40 °C to +45 °C
Storage: -40 °C to +60 °C

Photek Limited

26 Castleham Road, St Leonards on Sea,
East Sussex, TN38 9NS, United Kingdom.
T +44 (0)1424 850555 F +44 (0)1424 850051
E sales@photek.co.uk W www.photek.co.uk

Datasheet No.	DS006
Issue	DR
Date	24 August 2010

Power Supply & Gate Modules

Photek manufactures a range of power supplies and gate modules for our photomultipliers and photodiodes. Our power supplies use the very latest in power supply design and are available in a bench top format. Our gate modules provide transition times down to 2 ns with a 200 KHz repetition rate (model dependant) and are used for high brightness or fast optical shutter applications.

Pre-amplifier

Photek manufactures a 2 GHz bandwidth 20 dB gain pre-amplifier, the PA200-10 that is designed to be used with Photek's photomultipliers and photodiodes. The PA200-10 is used in close conjunction with the photomultiplier and photodiode to amplify the timing pulses for connection by a 50 ohm cable to oscilloscopes or other fast timing electronics.

Time Response

Pulse Rise Time (ps)

10 mm			
MCPs	Min.	Typ.	Max
0		50	
1	60	65	70
2	75	85	95
3		*	

25 mm			
MCPs	Min.	Typ.	Max
0	60	80	100
1		115	
2		*	
3	300	400	500

40 mm			
MCPs	Min.	Typ.	Max
0	60	80	100
1	100	150	200
2	180	230	280
3		350	

Pulse FWHM (ps)

10 mm			
MCPs	Min.	Typ.	Max
0		80	
1	100	110	120
2	130	150	170
3		*	

25 mm			
MCPs	Min.	Typ.	Max
0	100	150	200
1		170	
2		*	
3	800	1000	1200

40 mm			
MCPs	Min.	Typ.	Max
0	100	150	200
1	300	450	600
2	600	850	1100
3		1200	

* Available on request

Part Numbers

Part numbers start with PMT for photomultiplier and PD for photodiode, the part number is then built up in the following way:

MCP	Size	Input	Cathode	Gating
1	10	F (fibre)	CsI	NG (non gated)
2	25	Q (fused silica)	SB	G (gated)
3	40	M (MgF2)	BI	
			LNS20	
			S20	
			S25	

Example: PMT210/Q/S20/NG

Photek Limited

26 Castleham Road, St Leonards on Sea,
 East Sussex, TN38 9NS, United Kingdom.
 T +44 (0)1424 850555 F +44 (0)1424 850051
 E sales@photek.co.uk W www.photek.co.uk

Datasheet No.	DS006
Issue	DR
Date	24 August 2010

Mechanical

10 mm

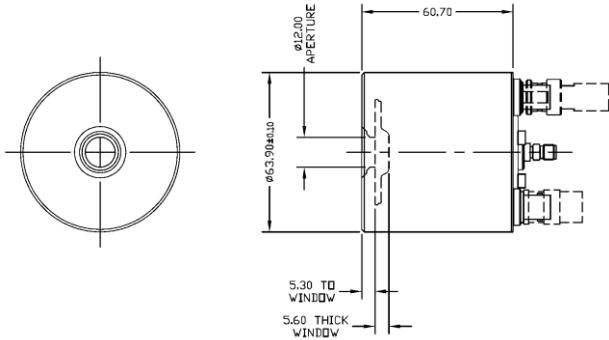

25 mm

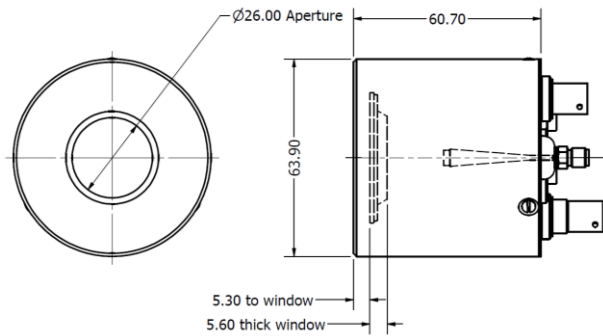

40 mm

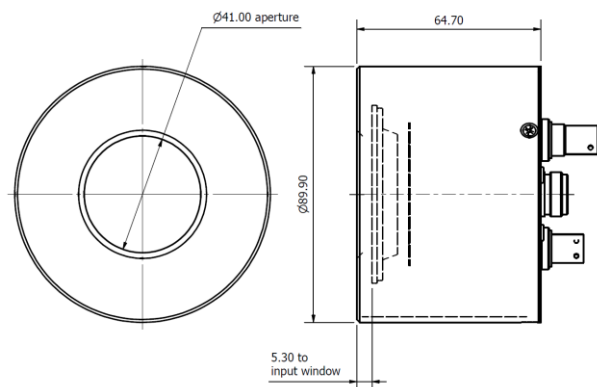

Dimensions are indicative and may vary depending on the optics, number of MCP's and housing required.

Photek Ltd reserves the right to update and improve this specification without prior notice

Datasheet No.	DS006
Issue	DR
Date	24 August 2010